

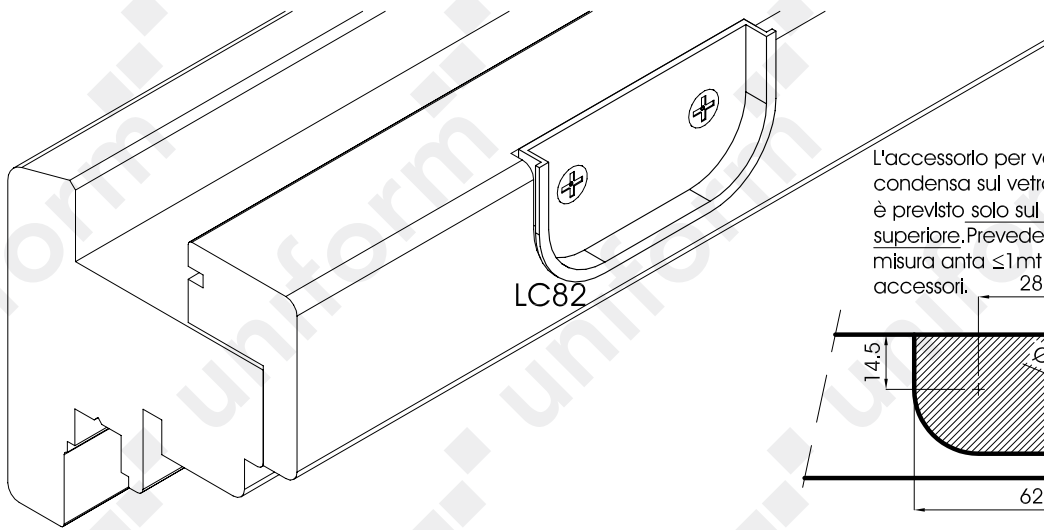

Verbund Complanare



LC82

L'accessorio per ventilazione evita la formazione di condensa sul vetro esterno stratificato. Il montaggio è previsto solo sul traverso inferiore e superiore. Prevedere n°2 pezzi su ogni traverso con misura anta ≤ 1 mt. Per misure > 1 mt prevedere n°3 accessori.

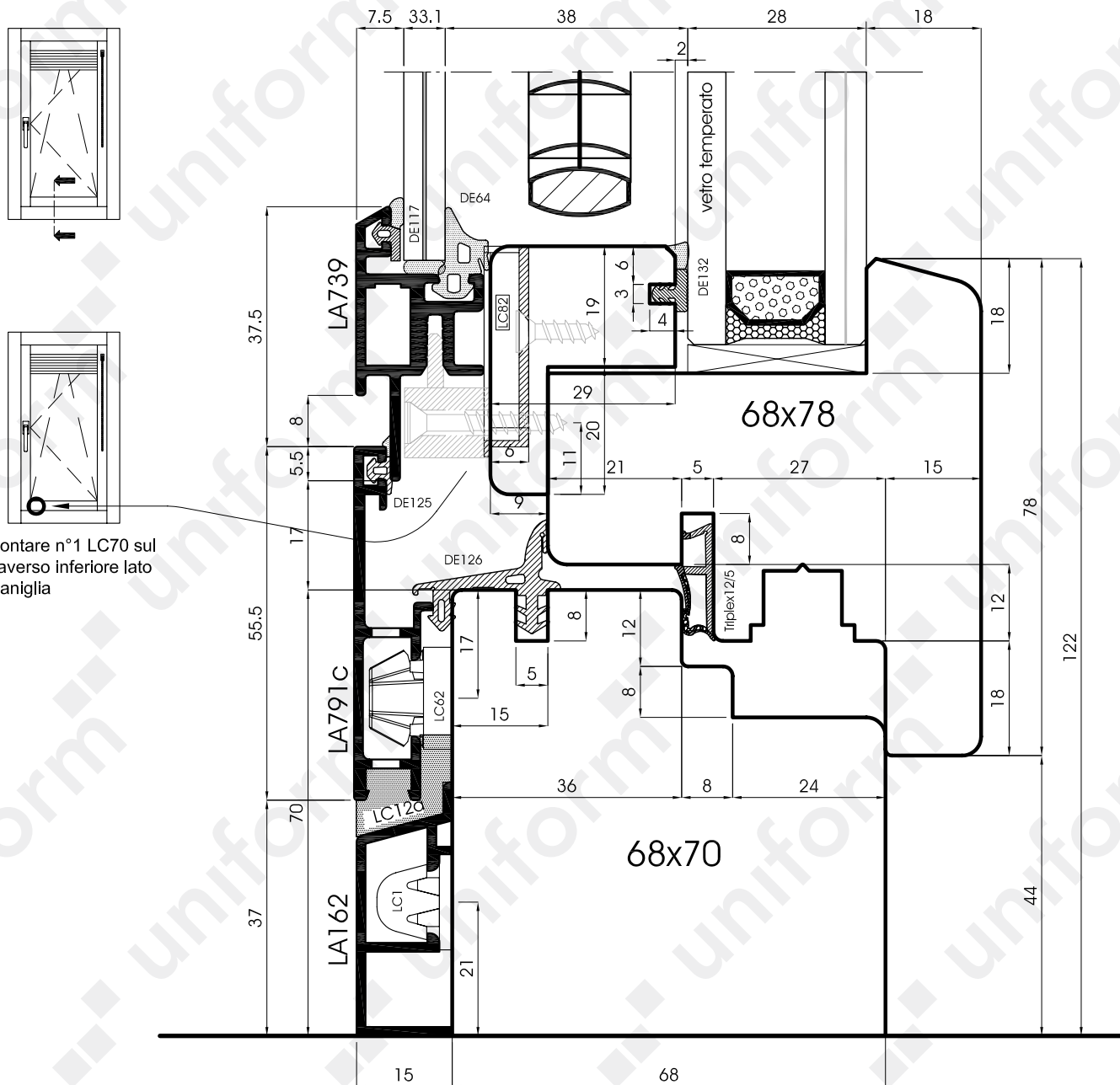
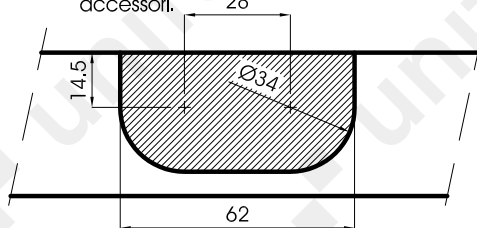

Montare n°1 LC70 sul traverso inferiore lato maniglia

Verbund Complanare

uniform

Scala 1:1

9.02

- Ⓘ Sezione verticale traverso inferiore finestra
- Ⓓ Vertikalschnitt Fenster quer unten
- Ⓔ Sección vertical travesaño inferior de la ventana
- Ⓕ Coupe verticale traverse inférieure fenêtr
- Ⓚ Vertical section of the window's lower ledger

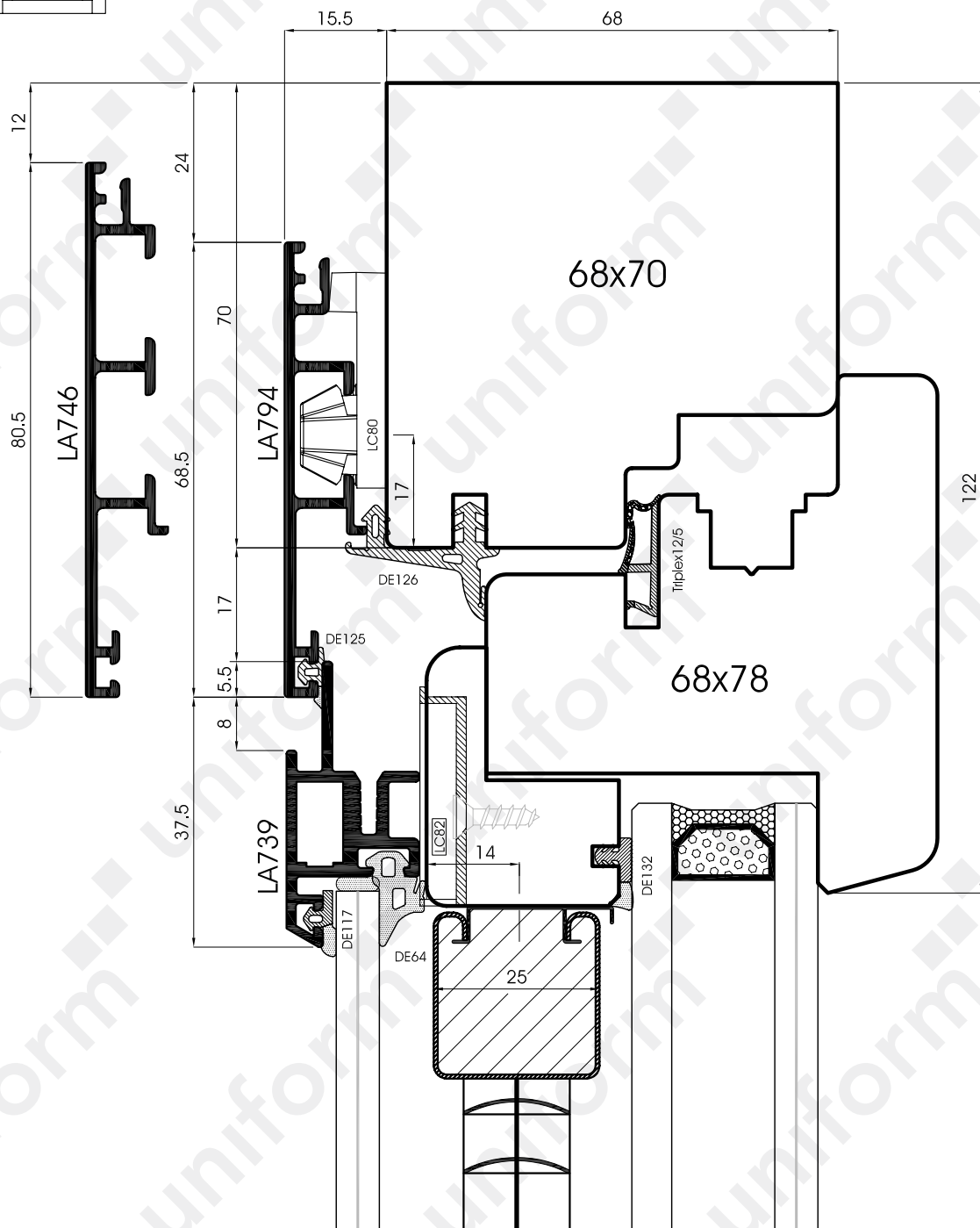
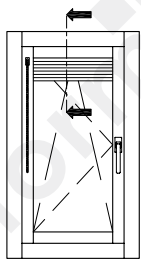

Verbund Complanare

uniform

Scala 1:1

9.03

- Ⓘ Sezione verticale traverso superiore finestra
- Ⓓ Vertikalschnitt Fenster quer oben
- Ⓔ Sección vertical travesañ superior de la ventana
- Ⓕ Coupe verticale traverse supérieure fenêtre
- Ⓚ Vertical section of the window's upper ledger

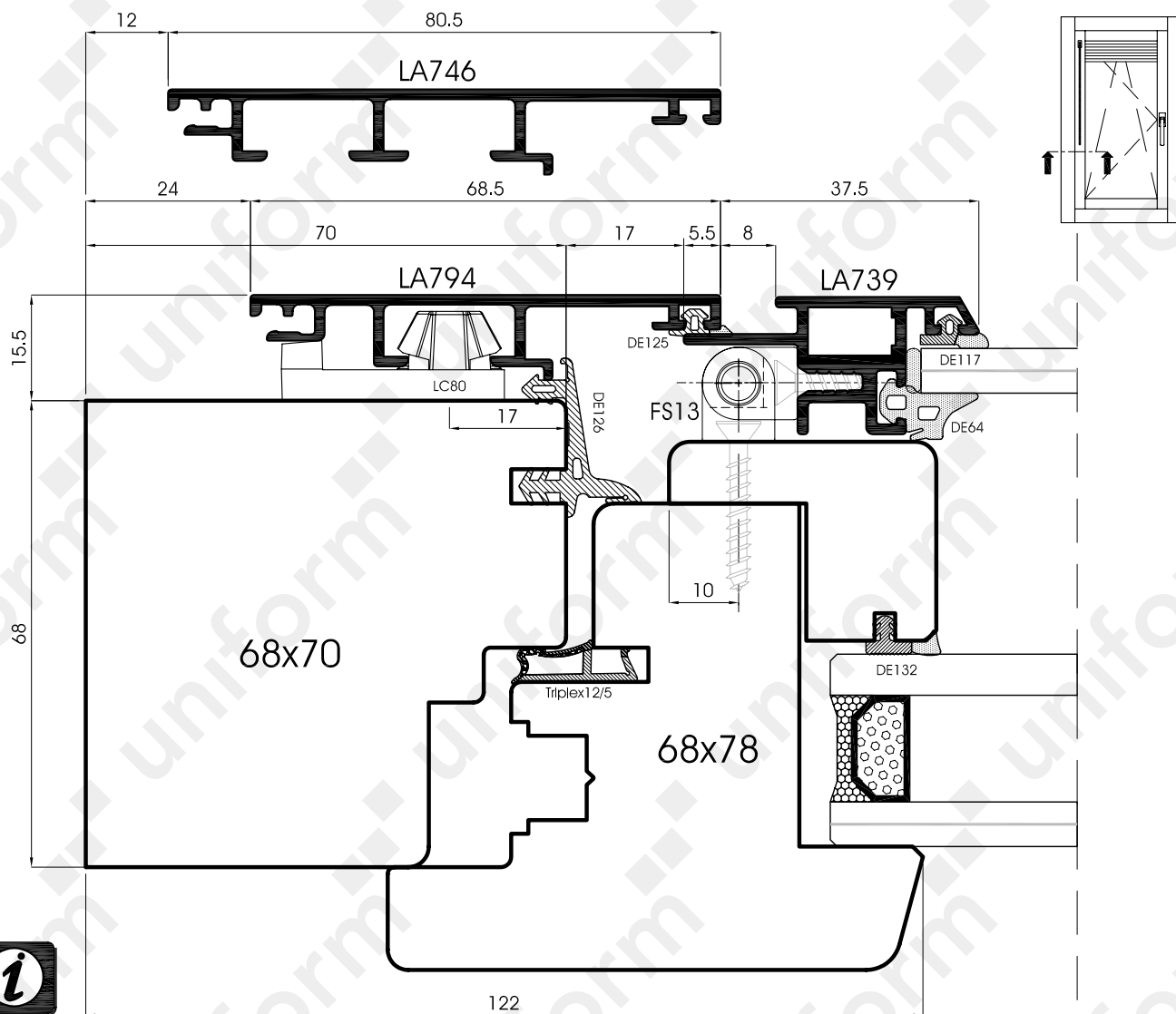

Istruzioni per montaggio cerniere FS13:

- 1) Montaggio della componente A sull'anta in legno con viti 3.5x25mm;
- 2) Centraggio dell'anta in alluminio LA739 in altezza mediante il montaggio nell'angolo inferiore opposto alla cerniera di n°1 LC70;
- 3) Montaggio della componente B sull'anta in alluminio con vite 3.5x13mm (Vedere pagine seguenti)
- 4) Bloccaggio con l'innesto del perno.

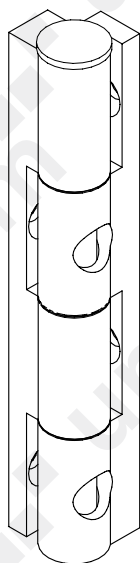

B

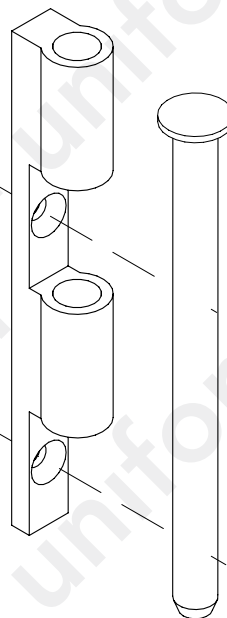

A

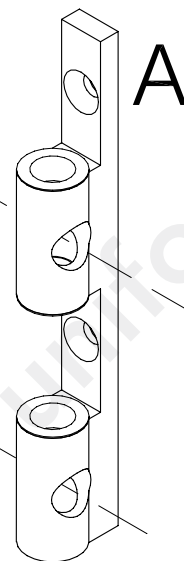

Verbund Complanare

uniform

Scala 1:1

9.04

- ① Sezione orizzontale montante laterale
- Ⓓ Horizontalschnitt senkrecht seitlich
- Ⓔ Sección horizontal montante lateral
- Ⓕ Coupe horizontale du montant latéral
- Ⓖ Horizontal section of the lateral jamb

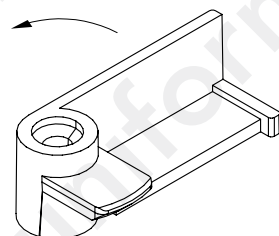
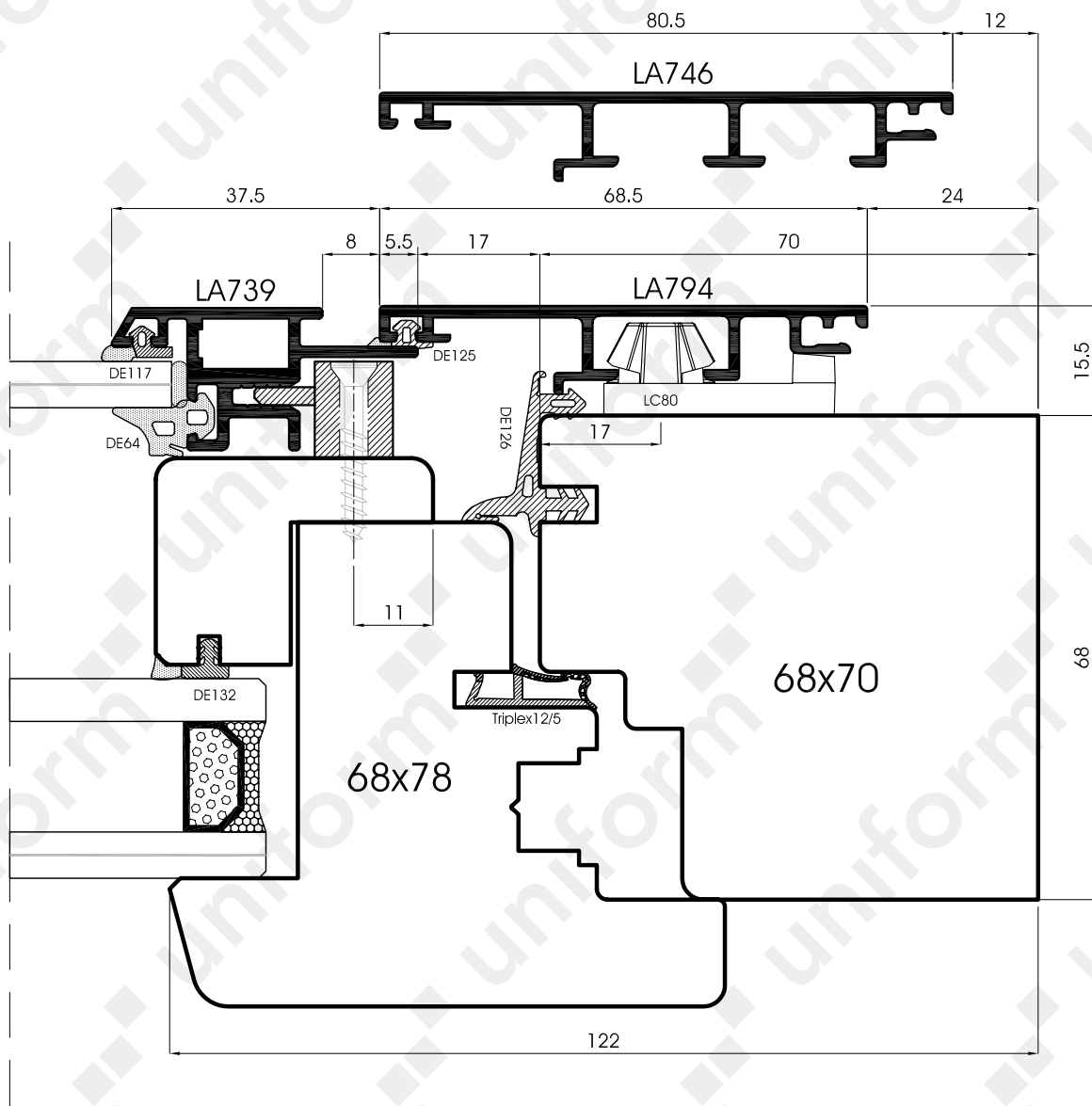
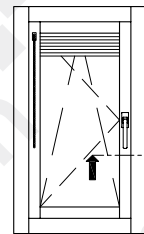

Clips LC70 girevoli per bloccaggio/apertura anta alluminio
(n°3 pz./mt)

Verbund Complanare

uniform

Scala 1:1

9.05

- Ⓘ Sezione orizzontale montante laterale
- Ⓓ Horizontalschnitt senkrecht seitlich
- Ⓔ Sección horizontal montante lateral
- Ⓕ Coupe horizontale du montant latéral
- Ⓚ Horizontal section of the lateral jamb

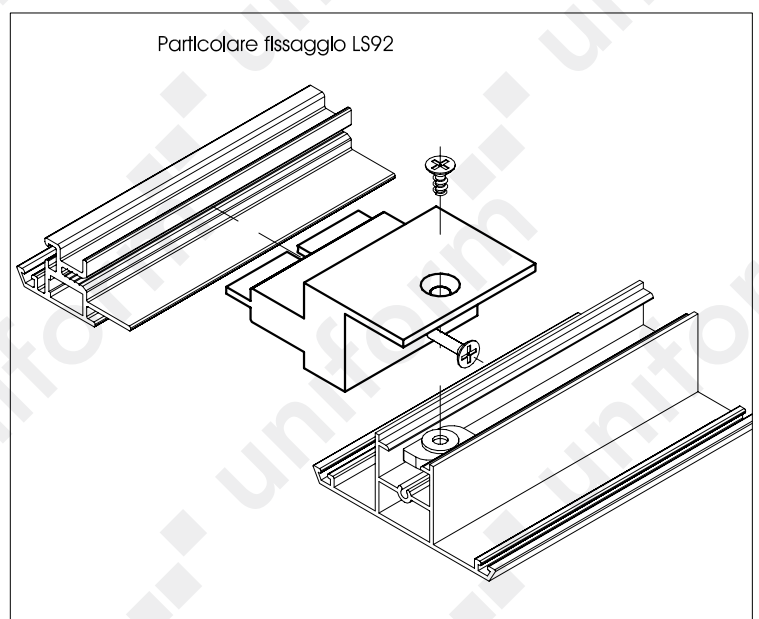
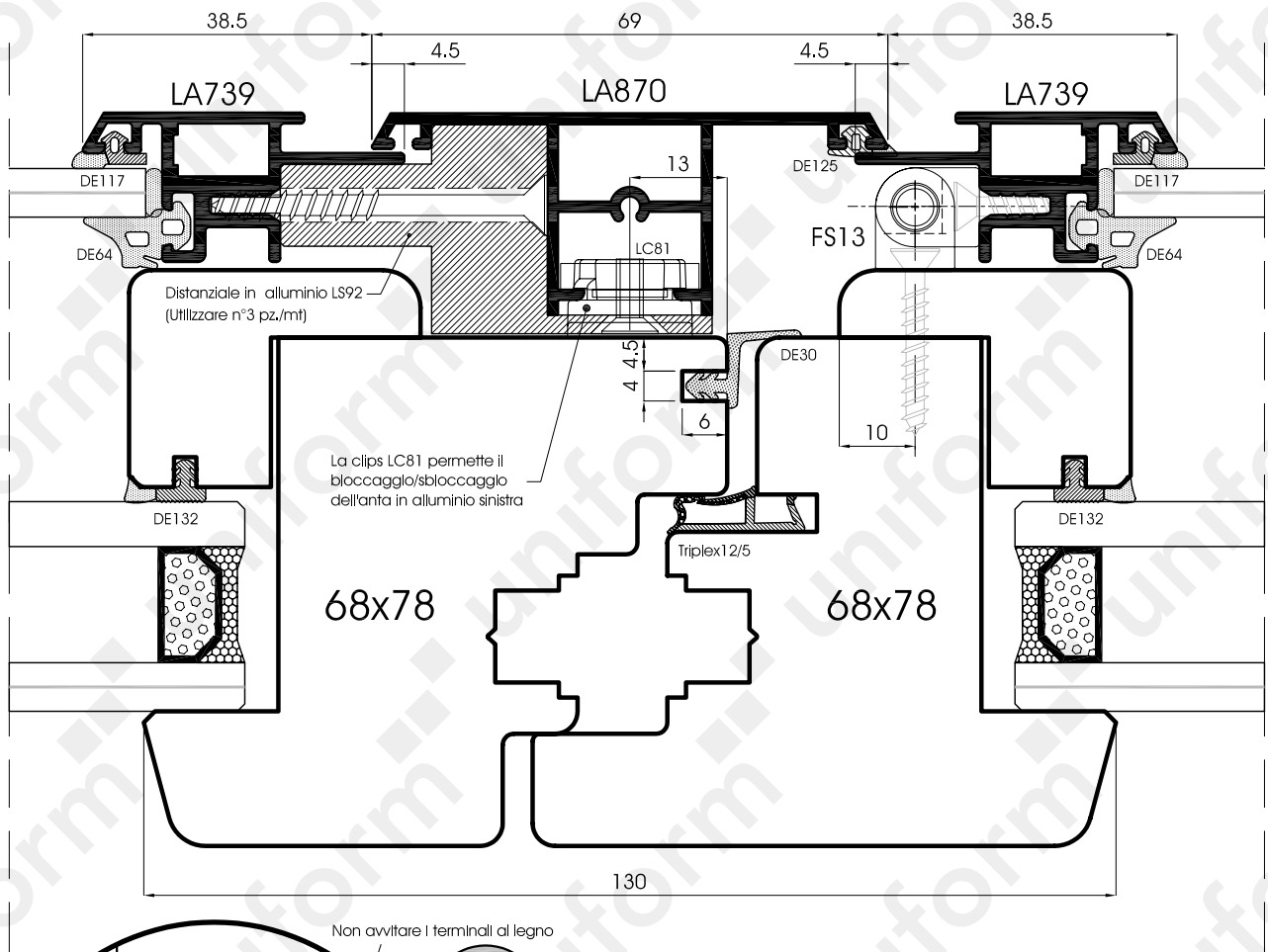
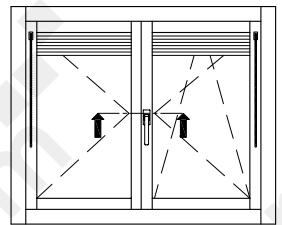

Verbund Complanare

uniform

Scala 1:1

9.06

- Ⓘ Sezione orizzontale chiusura centrale
- Ⓓ Horizontalschnitt Stulpprofil
- Ⓔ Sección horizontal del cierre central
- Ⓕ Coupe horizontale battement central
- ⒼⓀ Horizontal section of the middle clamp

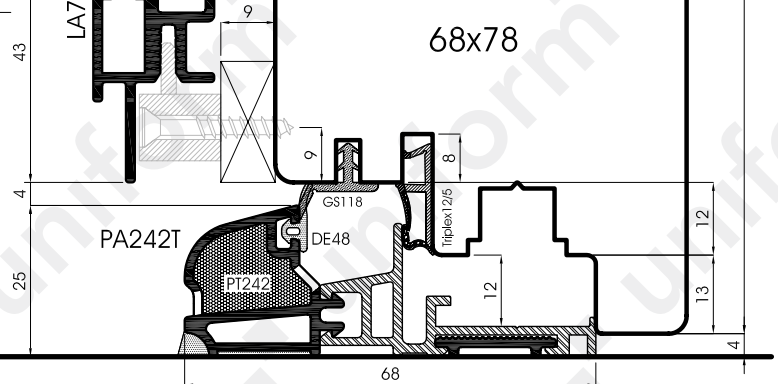
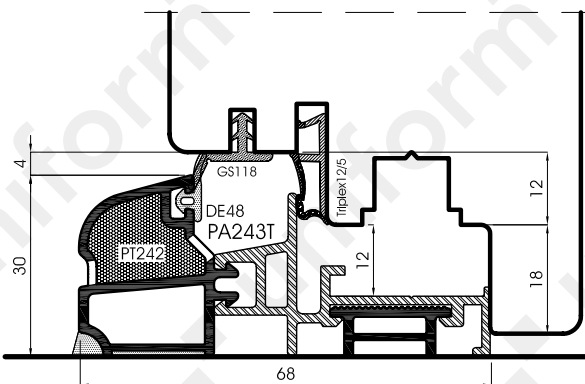
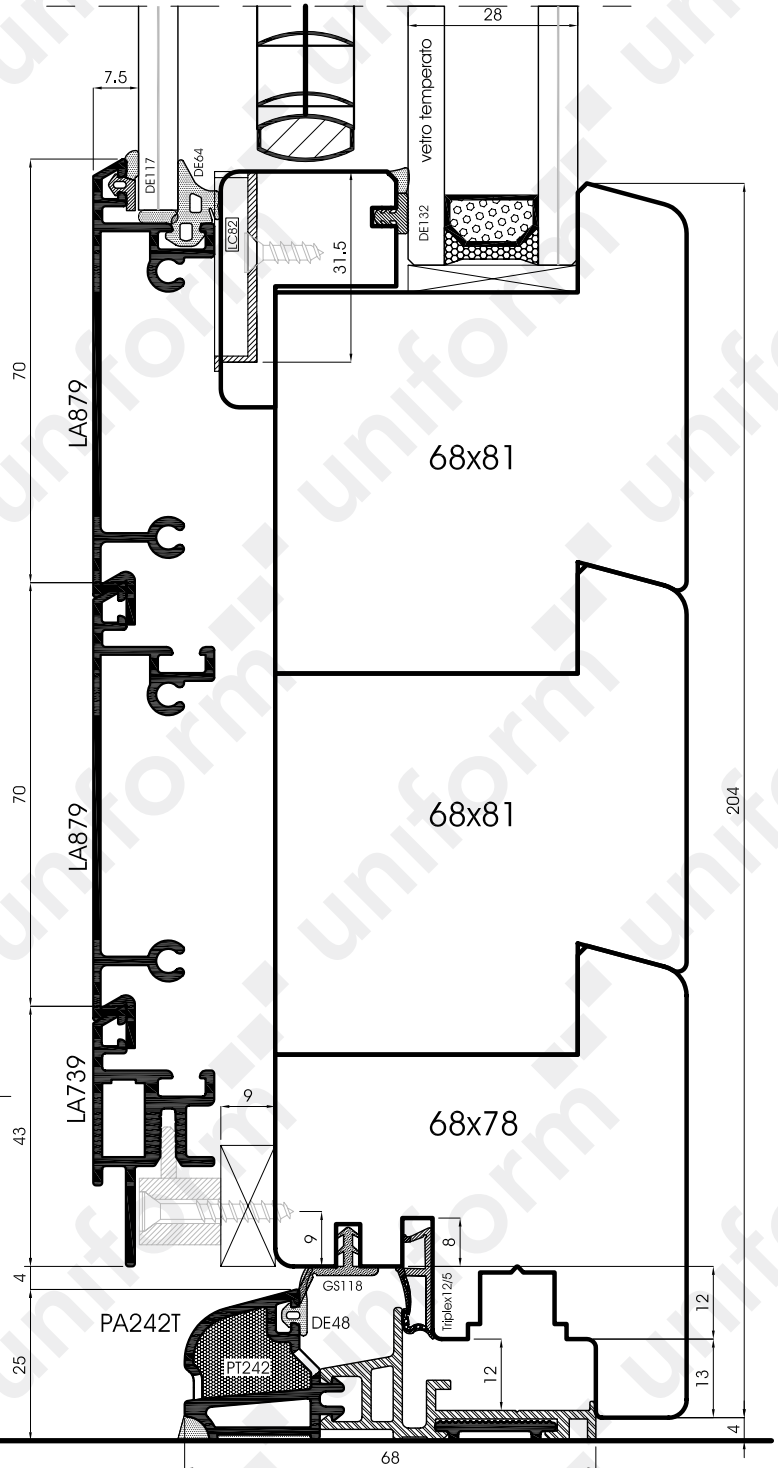
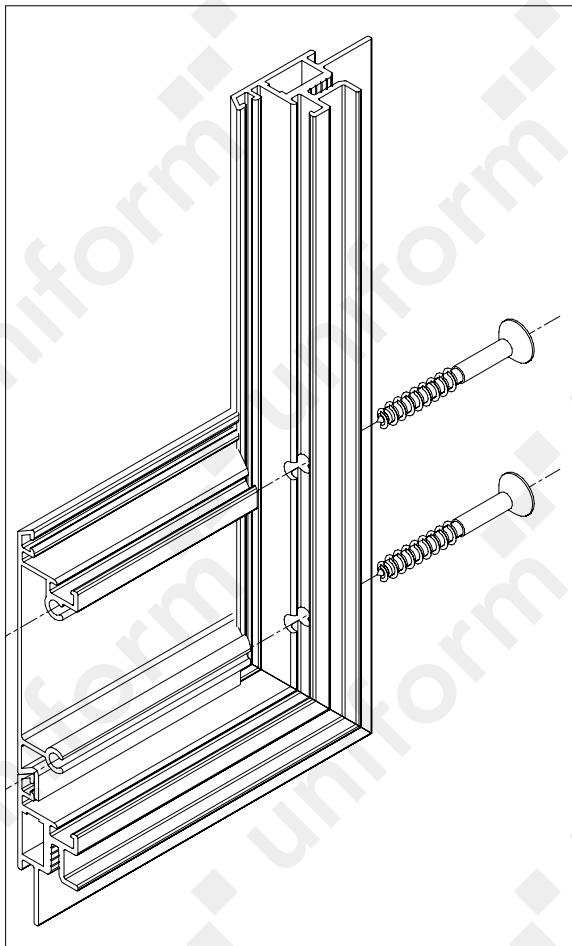
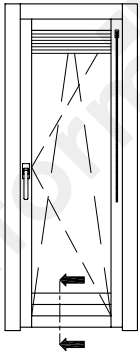

Verbund Complanare

uniform

Scala 1:1

9.07

- Ⓘ Sezione verticale trasverso inferiore portabalcone con PA242T-PA243T
- Ⓓ Vertikalschnitt Balkontür quer unten mit PA242T-PA243T
- Ⓔ Sección vertical travesaño inferior puertaventana con PA242T-PA243T
- Ⓕ Coupe verticale traverse inférieure porte-fenêtre avec PA242T-PA243T
- Ⓞ Vertical section of the balcony door's lower ledger with PA242T-PA243T

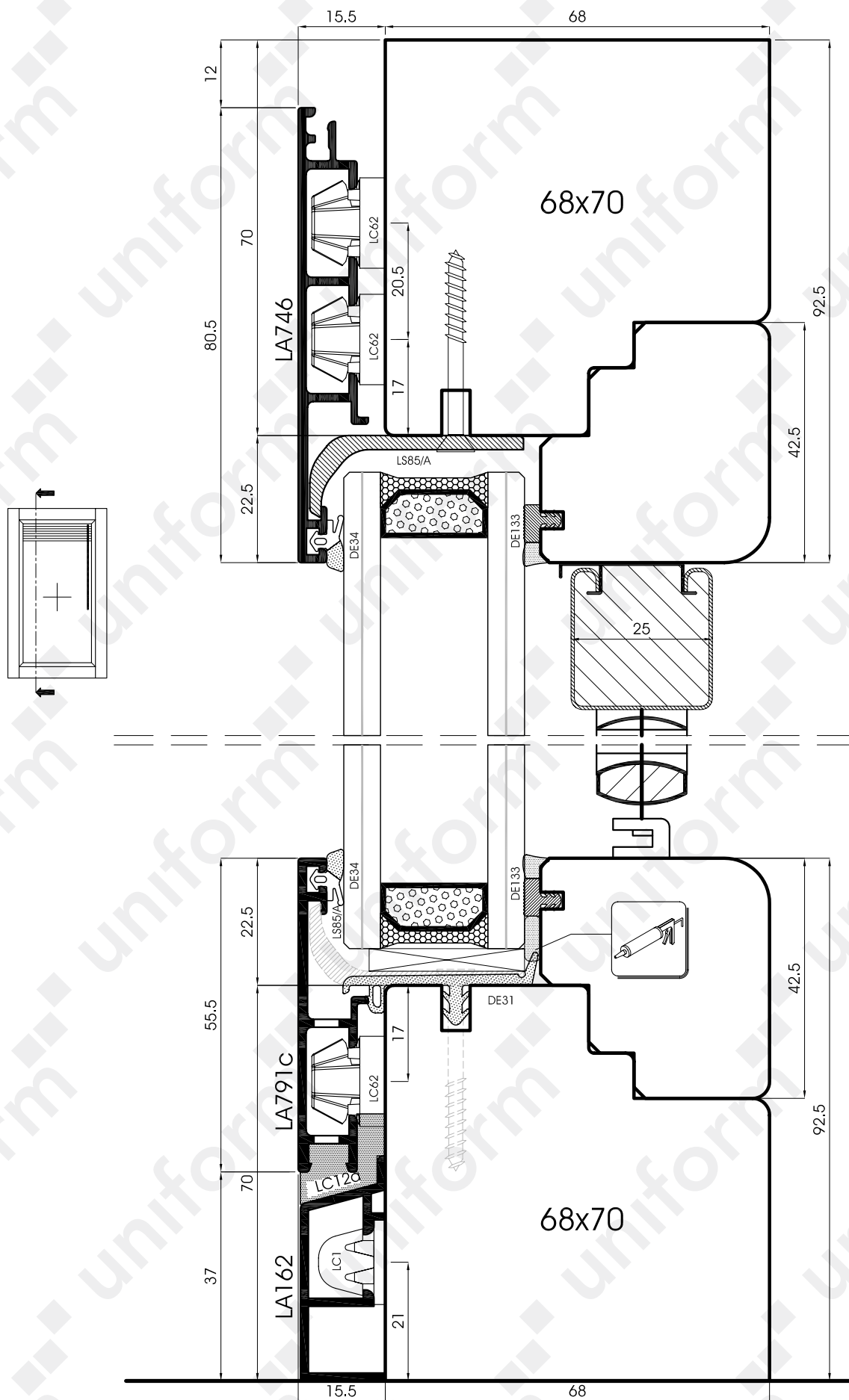

Verbund Complanare

uniform

Scala 1:1

9.08

- ① Sezione verticale finestra con vetro fisso
- ② Vertikalschnitt Fenster mit Fixverglasung
- ③ Sección vertical ventana con cristal fijo
- ④ Coupe verticale fenêtre avec vitre fixe
- ⑤ Vertical section of the window's lower ledger with fixed glass

Lavorazioni per inserimento cassonetto veneziana

Lato esterno

Montante anta(sopra)

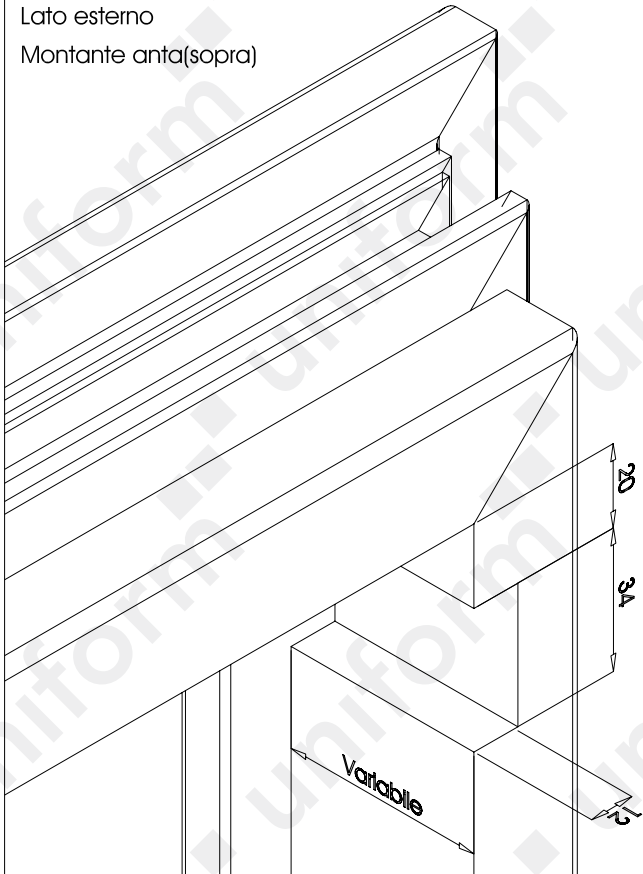

Lavorazioni per inserimento cassonetto veneziana

Lato interno

Montante anta(sopra)

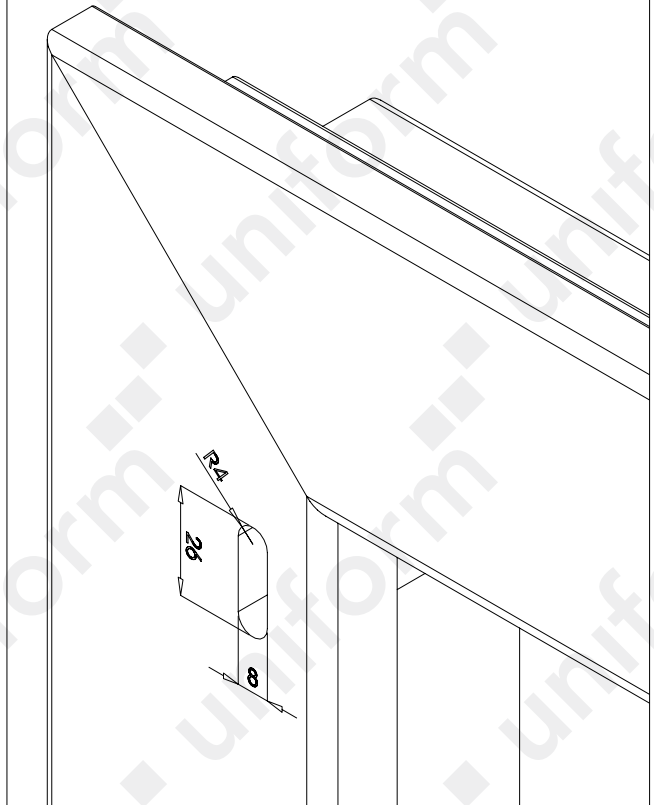

Lavorazioni per inserimento cassonetto veneziana

Lato esterno

Fermavetro lato superiore

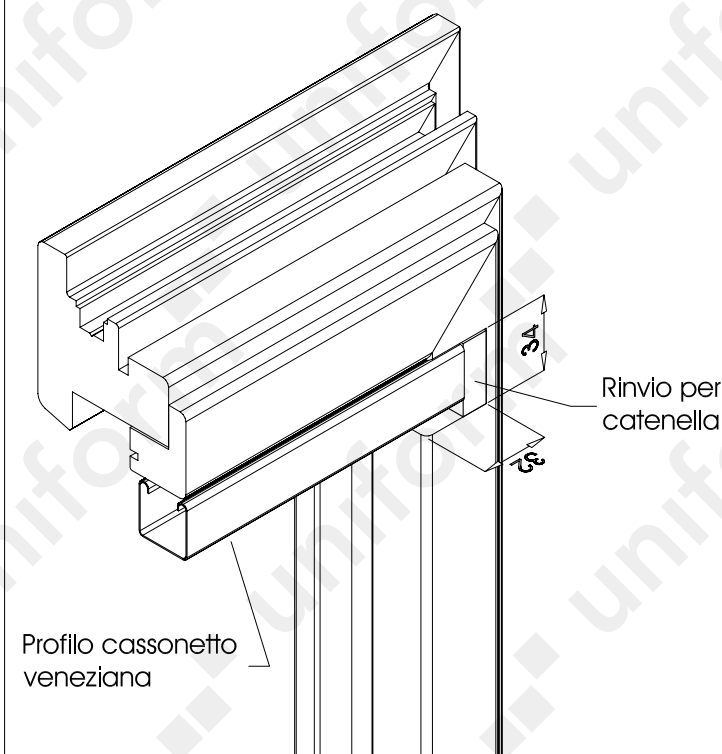

Sezione delle lavorazioni per inserimento veneziana

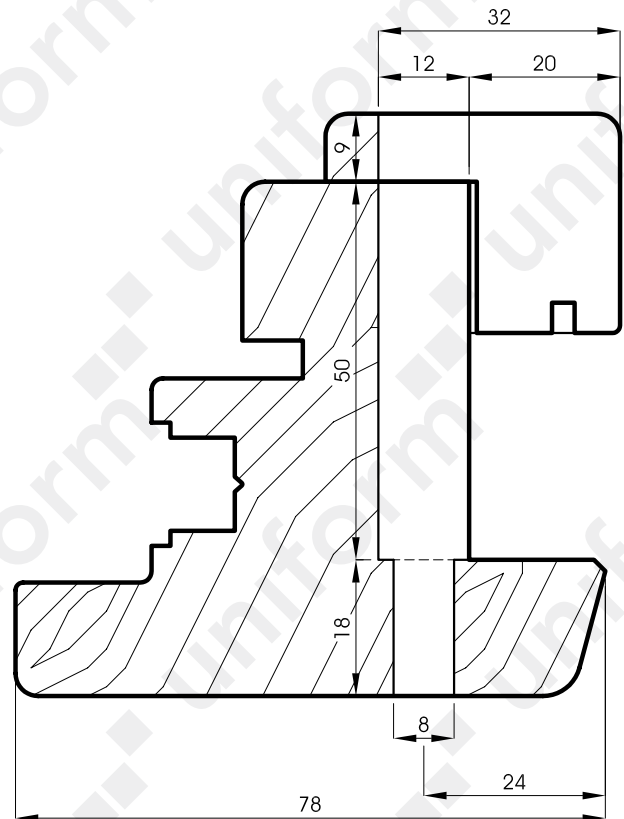

Verbund Complanare

uniform

Scala -

9.09

- Ⓘ Lavorazioni per inserimento veneziana
- Ⓓ Verarbeitung zum Einfügen der Jalousie
- Ⓔ Operaciones para insertar la cortina
- Ⓕ Usinage pour insertion store à lamelles
- Ⓚ Machining for the venetian blind's insertion processings



Dimensioni massime consigliate e n°cerniere
(misure esterno anta):

L(mm)	H(mm)	n°cerniere
≤ 800	≤ 1500	2
≤ 800	> 1500	3
> 800 max 1000	≥ 1500	4

Anta in alluminio LA739

Anta in legno

200 mm

Cerniera FS13

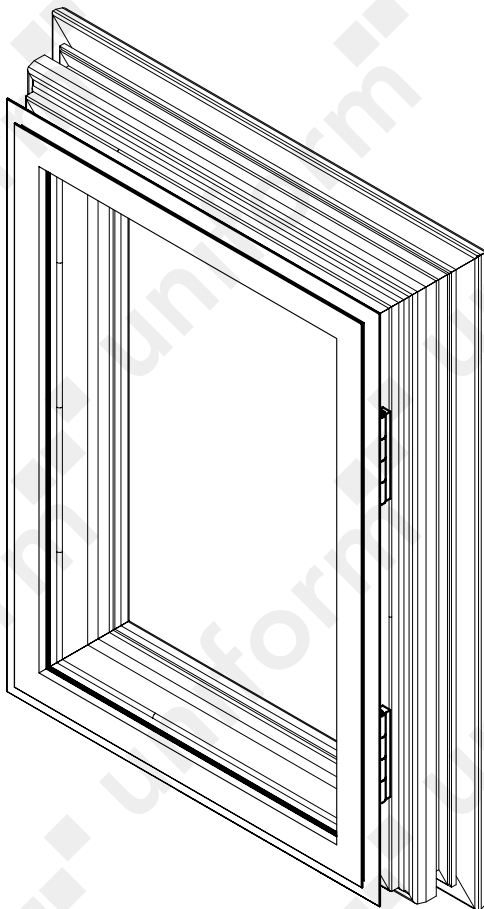

LC70

LC70

n°1 pezzo sul traverso inferiore(per centratura anta)

Verbund Complanare

uniform

Scala -

9.10

- Ⓘ Lavorazioni per inserimento FS13
- Ⓓ Verarbeitung zum Einfügen der FS13
- Ⓔ Operaciones para insertar la FS13
- Ⓕ Usinage pour insertion FS13
- Ⓜ Machining for the FS13 insertion processings

ALTRE TIPOLOGIE REALIZZABILI CON SISTEMA VERBUND COMPLANARE

	FATTIBILE	NON FATTIBILE	NOTE
Traverso intermedio anta		●	
Inglesine (con incollaggio al vetro)	●		Solo con profili LA137 e LA198
Sezione anta maggiorata per maniglia passante		●	
Finestra con sopra/sottoluca fisso	●		
Finestra con fisso laterale	●		
Piantoni e traversi intermedi telaio	●		
Finestre accoppiate	●		
Inserimento per tapparelle	●		
Inserimento zanzariere	●		
Telaio per ristrutturazione	●		
Inserimento in facciata	●		
Scorrevole parallelo	●		Ante con veneziana non ispezionabile
Bilico orizzontale		●	
Apertura esterna/antipanico		●	
Alzante scorrevole		●	
Fuorisquadra	●		Fattibile fuorisquadra solo sulla parte del telaio. Non fattibile anta fuorisquadra
Serramento ad arco	●		Fattibile arco solo sulla parte del telaio. Non fattibile anta ad arco

Verbund Complanare

uniform 

- ① Tipologie realizzabili con sistema Verbund Complanare
- ② Machbaren Elemente für Verbund system
- ③ Tipologías realizables por el sistema Verbund
- ④ Typologies réalisables avec le système Verbund
- ⑤ Available opening types with Verbund system